

DS-3WAP521-SI Wi-Fi 5 1200M In-Wall Access Point



DS-3WAP521-SI wireless access point is a new generation of panel 802.11AC AP products developed by IEEE 802.11 working group, the whole machine dual-frequency four-current, the maximum access rate of the whole machine 1.167Gbps, simple installation, can be installed on the 86mm panel cassette, without destroying the original decoration. Strong management ability. It is suitable for school dormitories, hospital wards, hotel rooms and other dense room places, solving the problem of poor signal quality in the traditional AP layout mode in these scenarios, and greatly reducing the installation cost and operating costs brought by the implementation.

- 2 Gigabit LAN Ports with 1 PoE Input
- 802.11ac Wave 2 1167 Mbps
- 86 mm Wall Junction Box for Easy Installation
- 50+ Concurrent User Connections
- Auto RF Optimization
- Support Intelligent Fast Roaming

▪ Specification

General	
Weight	0.2 kg (0.44 lb)
Installation Mode	In-Wall Mounting
Working Temperature	0 °C to 40 °C (32 °F to 104 °F)
Working Humidity	5% to 95% (no condensation)
Storage Temperature	-40 °C to 70 °C (-40 °F to 158 °F)
Storage Humidity	5% to 95% (no condensation)
Product Dimensions (W × H × D)	86 mm × 86 mm × 35 mm (3.38" × 3.38" × 1.37")
Packing List	1200 M Access Point ×1, Screw Pack × 1, Quick Start Guide ×1, Regulatory Compliance and Safety Information × 1
Power Consumption	Max. 8 W
WLAN Parameters	
Maximum Number of Clients	128
Recommended Number of Clients	50
Maximum Number of SSIDs	8
Working Frequency Band	radio 1: 5G(11a/n/ac), radio 2: 2.4G(11b/g/n)
Wi-Fi Standards	Wi-Fi 5
Wi-Fi Speed	2.4 GHz: 300 Mbps, 5 GHz: 867 Mbps
Spatial Streams	2.4 GHz, 2 × 2 , MU-MIMO, 5 GHz, 2 × 2 , MU-MIMO
Channel Width	2.4 GHz: Auto/20 /40 MHz, 5 GHz: Auto/20 /40 /80 / MHz
Number of Antennas	2.4GHz: 2; 5GHz: 2
Antenna Type	Built-in omnidirectional antennas
Antenna Gain	2.4 GHz: 3 dBi, 5 GHz: 3 dBi
Transmit Power	20 dBm
Modulation Technology	OFDM: BPSK@6/9Mbps, QPSK@12/18Mbps, 16-QAM@24Mbps, 64-QAM@48/54Mbps; DSSS: DBPSK@1Mbps, DQPSK@2Mbps, CCK@5.5/11Mbps; MIMO-OFDM (11n): MCS 0-15; MIMO-OFDM (11ac): MCS 0-9
Software Specifications	
WLAN Security	WAP-PSK, WAP2-PSK, WPA-WAP2-PSK, Blocklist & Allowlist, Support Multiple encryption key triggered dynamic unicast/multicast key update, Support Open system/shared key authentication, Support wireless endpoint access, Support 802.11i, Support SSID and VLAN binding
Management & Maintenance	Centralized AC management
Version Upgrade	upgrade on AC Web
Hardware Specifications	
Interface	1 × Gigabit RJ45 uplink port, 1 × Gigabit RJ45 port
Power Supply	IEEE 802.3af/at POE
LED Indicator	Yellow/green/blue for different working states, flashing mode
Reset Button	Hardware Resetting Button
Approval	
EMC	CE-EMC (EN 55032: 2015+A11: 2020, EN IEC 61000-3-2: 2019, EN 61000-3-3: 2013+A1: 2019, EN 50130-4: 2011+A1: 2014, EN 55035: 2017+A11: 2020)

Safety	CB (AMD1:2009, AMD2:2013, IEC 62368-1: 2014 (Second Edition), CE-LVD (EN 62368-1: 2014+A11: 2017),UL (UL 60950-1)
Chemistry	CE-RoHS (2011/65/EU),WEEE (2012/19/EU),Reach (Regulation (EC) No.1907/2006)
Radio	EN 301 893,EN 300 440,EN 62311,EN 301 489-3,EN 301 489-17

▪ **Typical Application**

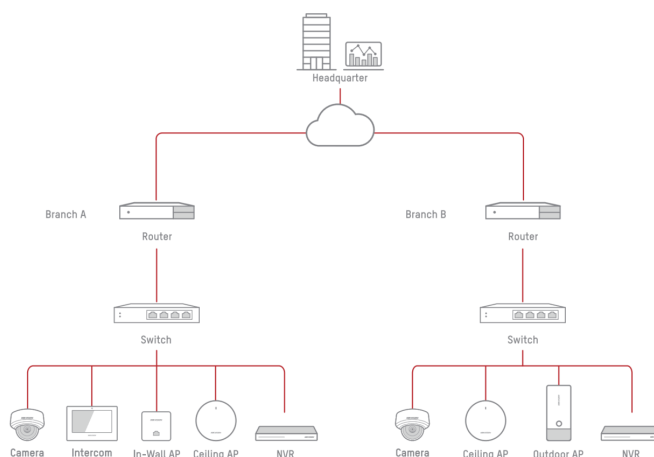

▪ **Physical Interface**

No.	Description
1	LAN Port
2	LAN Port with PoE Input

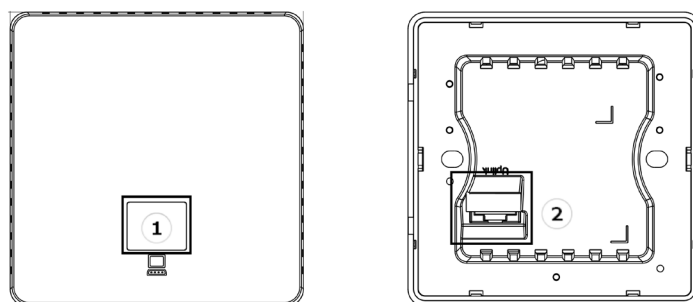

▪ **Available Model**

DS-3WAP521-SI

▪ **Dimension**

Headquarters

No.555 Qianmo Road, Binjiang District,
Hangzhou 310051, China
T +86-571-8807-5998
www.hikvision.com



Follow us on social media to get the latest product and solution information.

